

# LinRoc I

## Double piston system

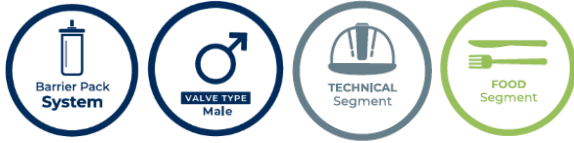

LinRoc I is a barrier pack system that specialises in dispensing high viscosity products such as glues, silicones, lubricants and food.

The system is available in a variety of can sizes and attachments are available to enhance the application.

### Product features:

- ✔ Designed for use with liquified propellant (HFO1234ze or R-152A ) as well as compressed gas
- ✔ Double piston with sealant separates the products from the propellant and compensate for irregularities on the can wall
- ✔ Up to 97% evacuation rate particularly with highly viscous products
- ✔ Available with 4mm or 7mm stem diameter
- ✔ True 360° usability for greater end-user experience
- ✔ Metal lever
- ✔ Ideal for highly viscous formulations
- ✔ Fast filling speed – filling done before the valve placement

### More info:

Visit: [www.lindalgroup.com](http://www.lindalgroup.com)

Email: [products@lindalgroup.com](mailto:products@lindalgroup.com)

Contact: Your local sales consultant



Your Innovation Partner

## Available accessories

### Spreaders (available with 7mm valve only)

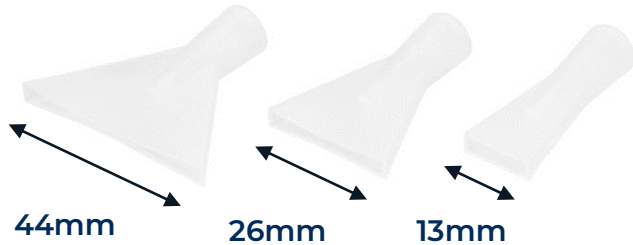

### Caps



## Technical details

### 1 High Delivery Valve

4mm or 7mm stem  $\varnothing$

### 2 Can

Standard

- 100 ml ( $\varnothing$ 45mm x H125mm)
- 200ml ( $\varnothing$ 45mm x H194mm)

**On request** (enabled by adjusting initial piston position in the can)

- 75ml ( $\varnothing$ 45mm x H125mm)
- 136ml ( $\varnothing$ 45mm x H194mm)
- 150ml ( $\varnothing$ 45mm x H194mm)

### 3 Double piston

- Double piston with sealant

### 4 Plug

- Supplied with or without plug
- PL001 plug for use with liquified propellant
- PL004 plug for use with compressed gasses

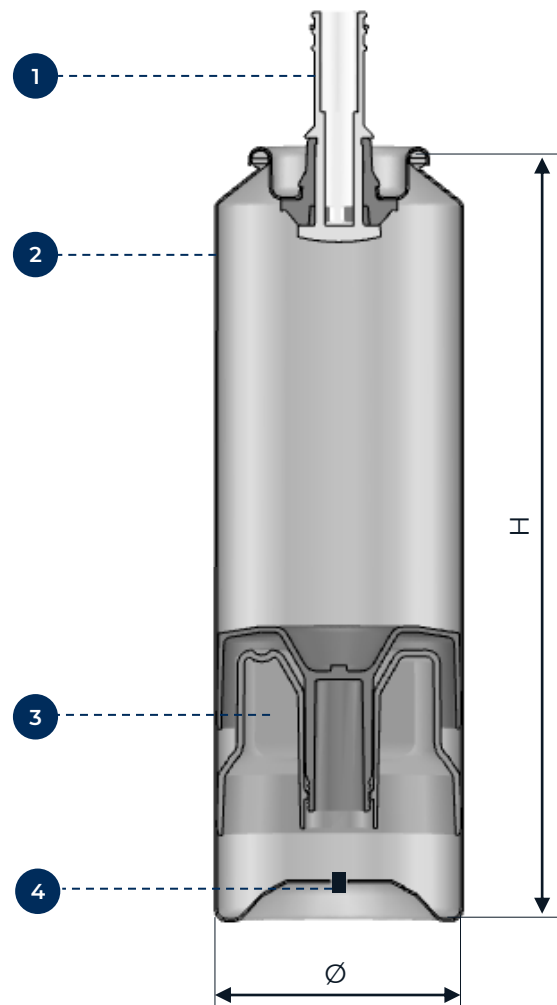

### More info:

Visit: [www.lindalgroup.com](http://www.lindalgroup.com)

Email: [products@lindalgroup.com](mailto:products@lindalgroup.com)

Contact: Your local sales consultant



Your Innovation Partner