

# ST940/50

## Insert-less spray head with overcap



An insert-less spray head actuator designed for gel applications in the personal care and pharmaceutical market segments.

### Product features:

- ✔ Foam or gel version available
- ✔ Matt finish actuator
- ✔ Overcap available in matt or gloss
- ✔ Various skirt heights available
- ✔ Compatible with LINDAL's LI, LIB and male Bag-on-valve (BOV)



### More info:

Visit: [www.lindalgroup.com](http://www.lindalgroup.com)

Email: [products@lindalgroup.com](mailto:products@lindalgroup.com)

Contact: Your local sales consultant



Your Innovation Partner

# ST940/50

Technical details

## Insert-less spray head with overcap

### Available configurations

- ✓ Foam or gel version available
- ✓ Compatible with LINDAL's LI, LIB and male Bag-on-valve (BOV)

### Technical details

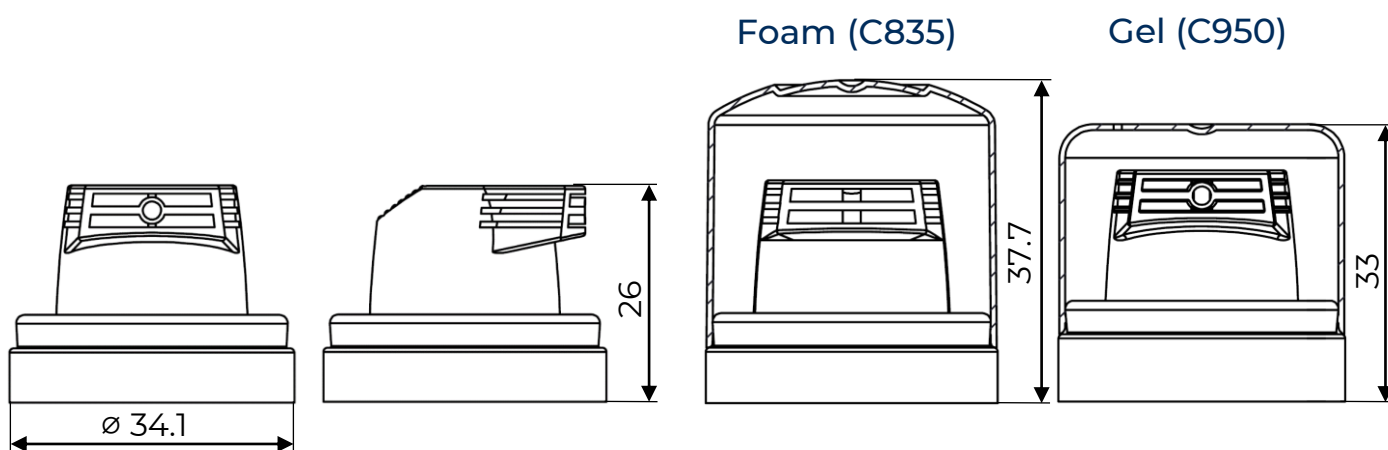

Compatible valves	LI, LIB, male BOV	Suitable cans	ST940 – Aluminium and Tinplate
Stem Ø	4mm		ST950 – Aluminium cans 35mm and above
Available insert	N/A		
Skirt size	ST940 – 5.5mm ST950 – 7mm	Available overcaps	C835 C950

**i** Further technical information is available on request

### Product packaging

- ✓ 1,800 units per box (with overcap)  
2,500 units per box (without overcap)
- ✓ 16 boxes per euro pallet (If 1,800 units per box)  
20 boxes per euro pallet (If 2,500 units per box)
- ✓ 28,800 units per pallet (If 16 boxes per pallet)  
50,000 units per pallet (If 20 boxes per pallet)

#### More info:

Visit: [www.lindalgroup.com](http://www.lindalgroup.com)

Email: [products@lindalgroup.com](mailto:products@lindalgroup.com)

Contact: Your local sales consultant



Your Innovation Partner