

# ST800

## Full cup actuator



A full cup actuator designed for applications in the home care, technical and food market segments.

### Product features:

- ✔ Ideal for upside down use
- ✔ Available with MBU (mechanical breakup) and non-MBU inserts
- ✔ Compatible with LINDAL's LI valve and male Bag-on-valve (BOV)



### More info:

Visit: [www.lindalgroup.com](http://www.lindalgroup.com)

Email: [products@lindalgroup.com](mailto:products@lindalgroup.com)

Contact: Your local sales consultant



Your Innovation Partner

# ST800

Technical details  
Full cup actuator

## Available configurations

- ✔ Compatible with LINDAL's LI valve and male Bag-on-valve (BOV)
- ✔ Available with MBU (mechanical breakup) and non-MBU inserts

## Technical details

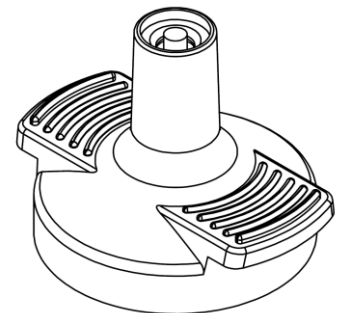
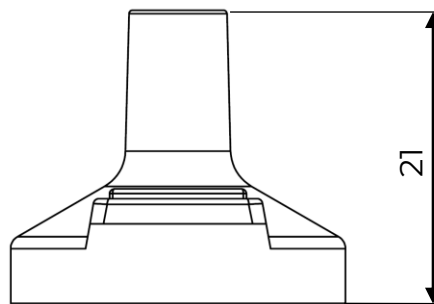
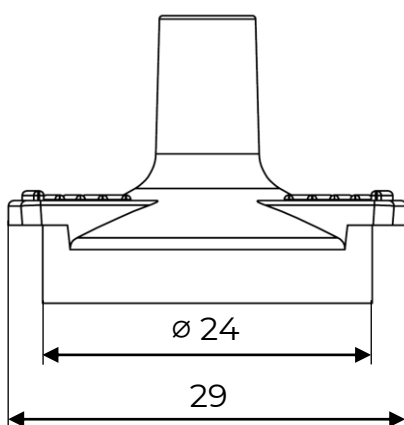

Compatible valves	LI, LIB, male BOV	Suitable cans	Aluminium Tinplate
Stem Ø	4mm	Available overcap	N/A
Available insert	C130 – 0.80mm (L.M)		
Skirt size	N/A		

**i** Further technical information is available on request

## Product packaging

- ✔ 4,500 units per box
- ✔ 18 / 24 boxes per euro pallet
- ✔ 81,000 / 108,000 units per pallet

### More info:

Visit: [www.lindalgroup.com](http://www.lindalgroup.com)

Email: [products@lindalgroup.com](mailto:products@lindalgroup.com)

Contact: Your local sales consultant