

Female BOV

Bag-On-Valve female



Your product inside the bag, the propellant outside the bag!

The Bag-on-Valve (BOV) aerosol system is a barrier package protecting the formulation from propellant and other influences, thus helping to prolong shelf life and improve end user experience.

Product features:

- ✔ Compressed air or nitrogen used as a propellant
- ✔ Total separation between product and propellant which improves protection and product shelf life
- ✔ True 360° usability for greater end-user experience
- ✔ Up to 99% evacuation rate depending on product viscosity
- ✔ Compatible with a wide range of Lindal standard actuators
- ✔ Suitable for a wide range of applications (spray, gels, creams, post-foaming gels etc.)
- ✔ Potential to minimise or eliminate usage of preservatives



More info:

Visit: www.lindalgroup.com

Email: products@lindalgroup.com

Contact: Your local sales consultant



Your Innovation Partner

Bag-On-Valve (BOV)

Technical details
Barrier pack system
female

1 Mounting cup
Tinplate
· Clear epoxy lacquer
Tin Free Steel (TFS) PET laminate
Aluminium
· Epoxy clear lacquer
2 Outer Gasket
Butyl
3 Inner Gasket
Neoprene, Buna, Butyl
4 Valve seat
Polyamide
5 Spring
Stainless steel
6 Housing
Polyethylene or Polypropylene
7 Diptube
Polyethylene
8 Foil Material
Multilayers with PP or PE

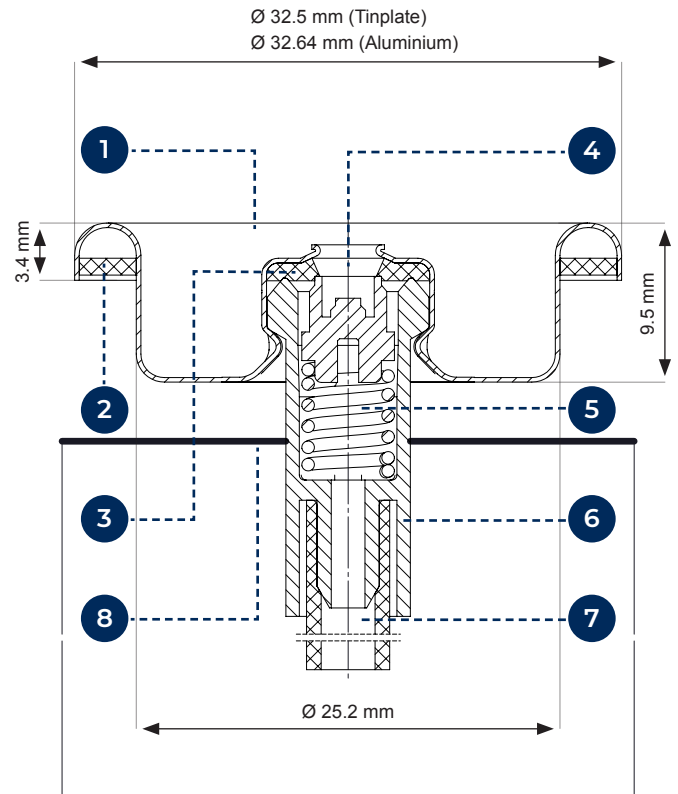

* Dimensions are subject to standard manufacturing tolerances

9 Available bag sizes
· Standard sizes ranging from 30ml to 400ml in Europe · Standard sizes ranging from 30ml to 600ml in Americas · Further sizes on demand
10 Quantity per carton
· Ranging from 600 to 1500 in Europe · Ranging from 900 to 2000 in the Americas

i Further technical information is available on request

More info:

Visit: www.lindalgroup.com

Email: products@lindalgroup.com

Contact: Your local sales consultant

