

# RT Valve

## Standard one-inch female valve



The RT Valve is a general purpose female valve, which is suitable for a wide range of applications across the technical market segment.

For use with a large variety of standard and custom actuators and spray caps.

### Product features:

- ✔ Ideal for technical products such as paint and adhesives
- ✔ Extensive specification combinations available
- ✔ Continuous spray



### More info:

Visit: [www.lindalgroup.com](http://www.lindalgroup.com)

Email: [products@lindalgroup.com](mailto:products@lindalgroup.com)

Contact: Your local sales consultant



Your Innovation Partner

# RT Valve

## Technical details Standard one-inch female valve

### 1 Mounting cup

Tinplate

- With or without dimples
- Plain or epoxy lacquer
- Polypropylene laminated

Tin Free Steel (TFS) PET laminate

Aluminium

- Without dimples
- Epoxy clear lacquer
- Epoxy gold lacquer + micoflex
- Epoxy silver lacquer + micoflex

### 2 Outer Gasket

Buna

### 3 Inner Gasket

Neoprene, Buna, Chlorobutyl, Butyl

### 4 Valve seat

POM

### 5 Spring

Stainless steel

### 6 Housing

Polyamide

- RTP sizes ranging from 0.5mm to 2mm
- VPH sizes ranging up to 0.75mm

### 7 Diptube

Polyethylene

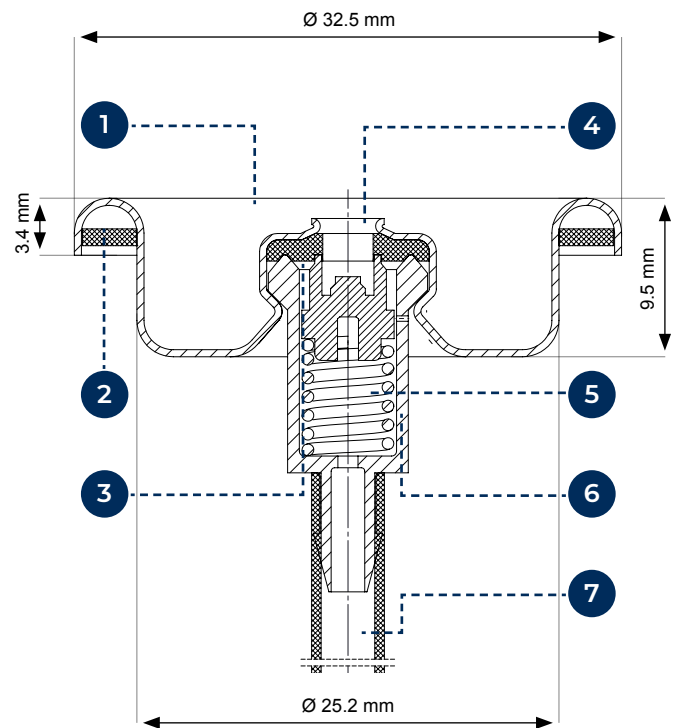

\* Dimensions are subject to standard manufacturing tolerances



**i** Further technical information is available on request

#### More info:

Visit: [www.lindalgroup.com](http://www.lindalgroup.com)

Email: [products@lindalgroup.com](mailto:products@lindalgroup.com)

Contact: Your local sales consultant



Your Innovation Partner