

# CA39 Valve

Standard one-inch male valve



The CA39 Valve is a general purpose male valve, which is suitable for a wide range of applications across personal care, technical, pharmaceutical and food market segments.

For use with a large variety of standard and custom actuators and spray caps.

## Product features:

- ✔ Specifically designed for the more difficult to handle powder formulations
- ✔ Extensive specification combinations available
- ✔ Continuous spray



## More info:

Visit: [www.lindalgroup.com](http://www.lindalgroup.com)

Email: [products@lindalgroup.com](mailto:products@lindalgroup.com)

Contact: Your local sales consultant



Your Innovation Partner

# CA39 Valve

Technical details

## Standard one-inch male valve

### 1 Mounting cup

Tinplate

- With or without dimples
- Plain or epoxy lacquer (clear or gold)

Aluminium

- With or without dimples
- Epoxy clear lacquer
- Epoxy gold lacquer + micoflex

### 2 Outer Gasket

Buna, Butyl

### 3 Inner Gasket

Neoprene, Buna, Chlorobutyl, Butyl

### 4 Valve stem

POM

- 3.3mm stem  $\varnothing$
- 1 stem orifice with 0.46mm  $\varnothing$  to 0.76mm  $\varnothing$

### 5 Spring

Stainless steel

### 6 Housing

POM

- RTP sizes ranging from 0.46mm to 2.29mm
- VPH sizes ranging up to 0.64mm

### 7 Diptube

Polyethylene

- Available with straight cut or V cut

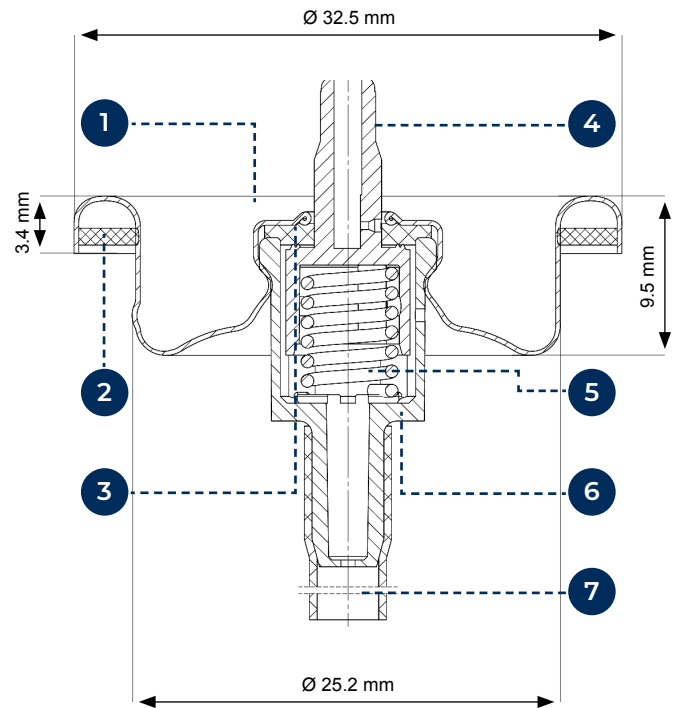

\* Dimensions are subject to standard manufacturing tolerances



**i** Further technical information is available on request

### More info:

Visit: [www.lindalgroup.com](http://www.lindalgroup.com)

Email: [products@lindalgroup.com](mailto:products@lindalgroup.com)

Contact: Your local sales consultant



Your Innovation Partner